



Date
Quote #
Project Name
Type



SMRF- Wall Mount

Description:

Die cast aluminum housing with full face design. All external hardware is stainless-steel.

Name - Size - Engine - Lumens - CCT - Electrical - Mounting - Lens - Pattern - Options - Finish

Name	Light Engine	Source Lumens _{(LED)(5000K)}	Color Temp	Electrical
SMRF	24 LED (Max)	3120	3000K	UNV 120-277V
			3500K	HLV 347-480V
			4000K	
			5000K	

Contact for custom

Contact for custom

Contact for custom

Mounting		Lens		Light Pattern		Options		Finishes	
WM	Wall mount	FG	Frosted glass lens (Std)	F	Front light	PC	Button photocell	BL	Black
RTC	Recessed in concrete	OPL	Opal polycarbonate lens			SF	Single fuse	WH	White
						TP	Tamperproof hardware	SG	Silver Grey
						TS	Tamperproof screws	BZ	Bronze
						WL	Wet location	CC	Custom Color
						ELB	Electronic HID ballast		See website for custom colors. Contact factory for physical samples.
						CAG	Cast aluminum guard		
						DB	Deeper back box		

- Lumens are based on max wattage & 5000K CCT
- IES files available upon request
- Std - Standard Offering





Dimensions & Mounting:

Please note that drawings are not to scale.

Front view

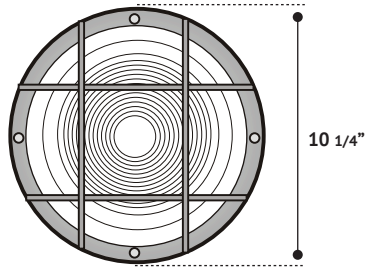

WM - wall mount

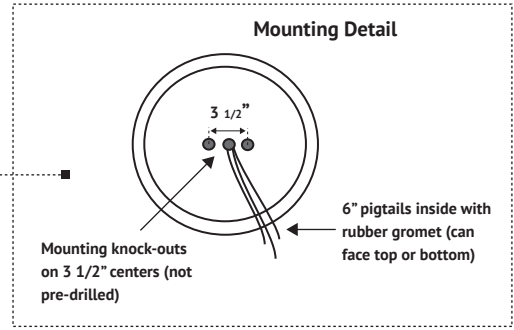
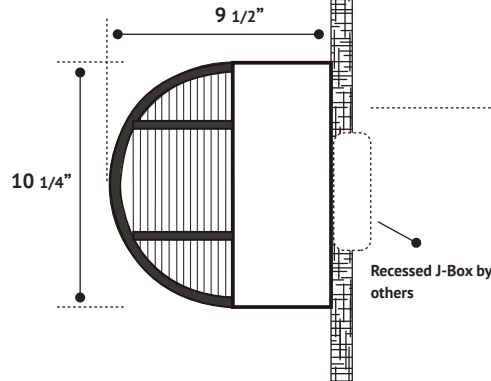

RTC - Recessed in concrete

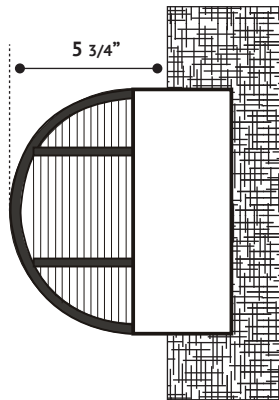

Listing:

Complies to CSA and UL standards.

Polar Graph:

