

Date:

Type:

Project:

ROCK BOLLARD

A slim bollard with flat top and uniquely curved side. Made of aluminum extrusion. The top section houses the LED giving subtle downward illumination. Contact Solera for the column version.



Name	Size	Lamping	Lumens*	Color Temp	Electrical	Mounting
ROCK-BLD	42	30W LED	5280	3000K 3500K 4000K 5000K	UNV 120-277V HLV 347-480V	ABT Anchors, Bolts & Template
Contact for other heights		Contact for other wattages		Specify other		Contact for other mounting version

Lens	Light Pattern	Options	Finishes
FL Frosted lens (Std)	D Down light (Std)	DM 0-10V Dimming SS Stainless steel construction	BL Black BZ Bronze WH White SG Silver Grey BA4 Brushed Aluminum #4 CC Custom Color
See finishes info on website			

*Lumens are based on Wattage and 5000K CCT
 *Specific IES Files available upon request
 Std – Standard Offering

ROCK-BLD- _____

Customization Notes:

→ Info on this spec sheet will change without notice as product development is an ongoing process.

Dimensions (drawings are not to scale; all dimensions in inches)

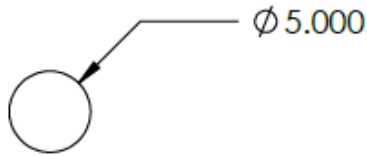

Top View

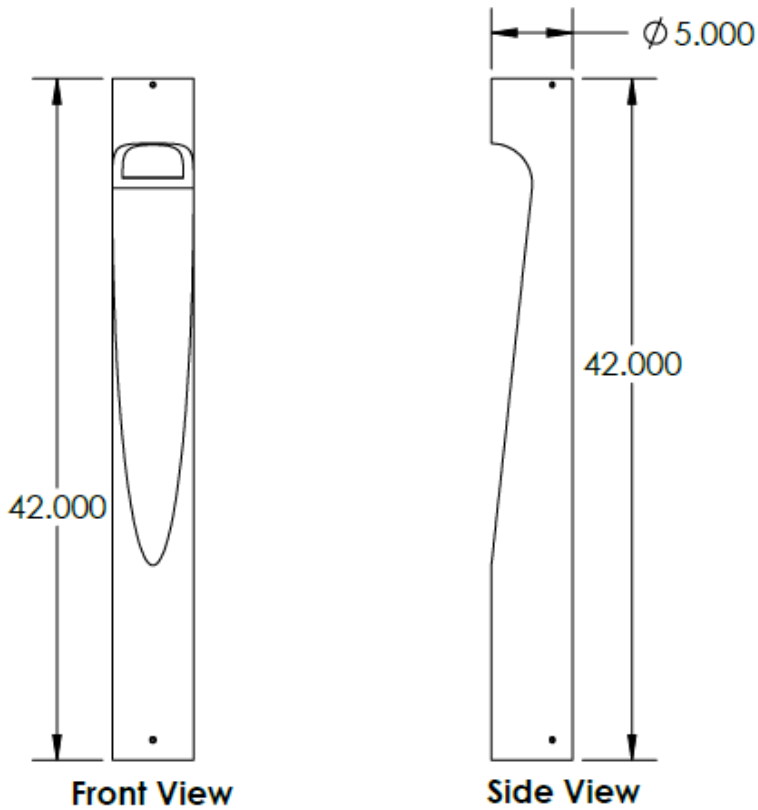

Front View

Side View



Anchoring Details (not to scale; dimensions in inches)

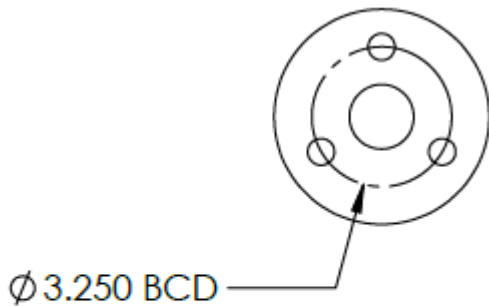

Anchorbolt Size: 1/2" X 12" X 1-3/8"

- Hot dipped Galvanized anchor bolts
- Galvanized steel hex nuts
- Galvanized steel flat washers